

Topwall Adapters

TOPWALL DUAL E ADAPTERS

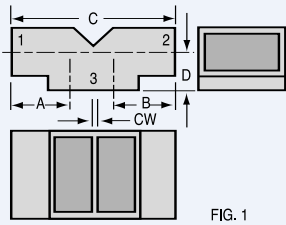

FIG. 1

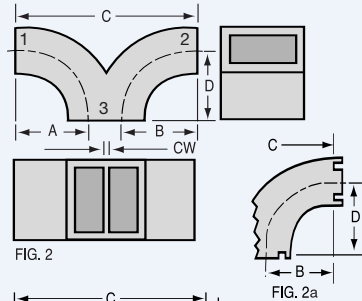

FIG. 2

FIG. 2a

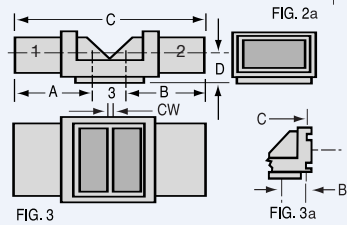

FIG. 3

FIG. 3a

TOPWALL E AND STRAIGHT ADAPTERS

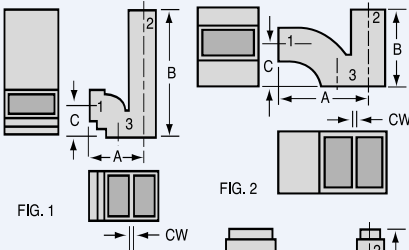

FIG. 1

FIG. 2

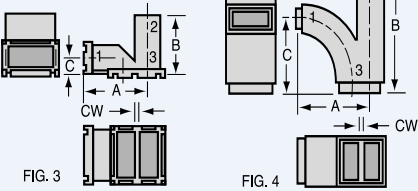

FIG. 3

FIG. 4

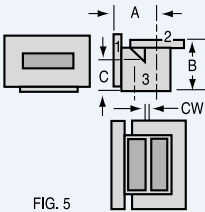

FIG. 5

TOPWALL H AND STRAIGHT ADAPTER

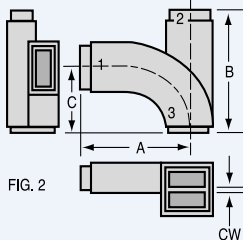

FIG. 2

CW

W/G	FIG	C/W	Terminals			MDL Model Number	Dimensions			
			1	2	3		A	B	C	D

Topwall Dual E Adapters

WR51	1	.040	W/G ¹	W/G ¹	W/G	51JT32	.42	.42	1.14	.25
WR62	2	.090	W/G ¹	W/G ¹	W/G	62JT12	.69	.69	1.78	.50
WR90	2	.050	W/G ²	W/G ²	W/G	90JT22	.99	.99	2.43	.75
	2a	.050	Corral	Corral	Corral	90JT112	.90	.90	2.25	.90
	3	.050	W/G	W/G	W/G	90JT62	1.03	1.03	2.50	.39
	3a	.050	Corral	Corral	W/G	90JT52	.33	.33	1.10	.39
	2	.120	W/G ²	W/G ²	W/G	90JT12	.99	.99	2.50	.75
WR112	2a	.120	Corral	Corral	Corral	90JT122	.90	.90	2.32	.90
	3	.120	W/G	W/G	W/G	90JT72	1.03	1.03	2.57	.39
	3a	.120	Corral	Corral	W/G	90JT82	.33	.33	1.17	.39
	3	.064	W/G ³	W/G ³	W/G	112JT32	.86	.86	2.28	.45
	3a	.064	Corral	Corral	W/G	112JT42	.34	.34	1.25	.45
	3	.150	W/G ³	W/G ³	W/G	112JT12	.86	.86	2.37	.45
	3a	.150	Corral	Corral	W/G	112JT22	.34	.34	1.34	.45

- Notes: ¹ If flange is required use UG type choke or butt-type cover. Add .250 to A or B dimensions.
² If flange is required use UG type choke or butt-type cover. Add .312 to A or B dimensions.
³ If UG choke is required add .44 to A or B dimensions.

W/G	FIG	C/W	Terminals			MDL Model Number	Dimensions		
			1	2	3		A	B	C

Topwall E and Straight Adapters

WR51	1	.040	W/G ¹	W/G	W/G	51JT12	.66	1.48	.36
WR62	2	.090	W/G ¹	W/G	W/G	62JT22	1.09	.90	.50
WR90	3	.050	Corral	W/G	Corral	90JT92	1.50	1.14	.32
	3	.050	90FA92 ²	90FA92 ²	Corral	90JT14	1.53	1.12	.32
	4	.120	W/G ³	W/G	W/G	90JT32†	1.72	3.16	1.74
	3	.120	Corral	W/G	Corral	90JT102	1.57	1.14	.32
	3	.120	90FA92 ²	90FA92 ²	Corral	90JT24	1.60	1.12	.32
B137	5	.150	B137FA12 ²	B137FA12 ²	W/G	B137JT14	1.17	1.36	.82

(1.372x0.487 ID)

- Notes: ¹ If flange is required use UG type choke or butt-type cover. Add .250 to A dimension.
² Flange integrally cast. See flange specification table, page 46.
³ If flange is required use UG type choke or butt-type cover. Add .312 to A dimension.
† OD of all terminals are machined to accept ID of flanges.

W/G	FIG	C/W	Terminals			MDL Model Number	Dimensions		
			1	2	3		A	B	C

Topwall H and Straight Adapter

WR90	2	.120	W/G	W/G	W/G	90JT42†	2.54	2.84	1.48
------	---	------	-----	-----	-----	---------	------	------	------

- Notes: † OD of all terminals are machined to accept ID of flanges.